



# 4x4 Equip™

Quality 4x4 Accessories & Camping Gear

4x4equip.com.au



Wire Light Holder

Combo Shovel

Telescopic Light or Shower Pole

2Kg (4lb) Fibreglass Handled Axe



Axe & Shovel NOT included

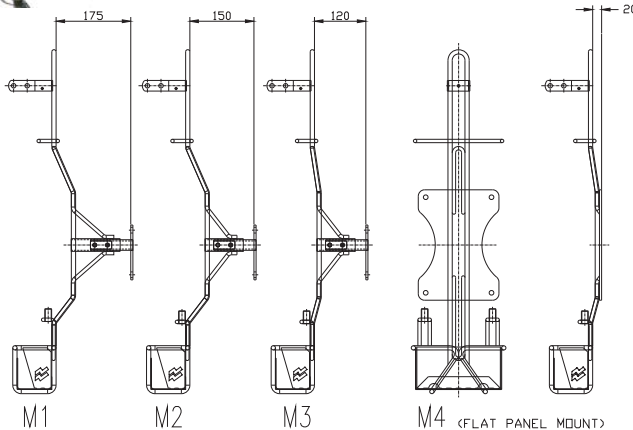

OFF-SET MODELS AVAILABLE

**Standard Features:**

- Australian designed & manufactured
- Handle retaining pin & padlock
- Rubber strap
- Zinc plated & powder coated
- Garage storage bracket
- Choice of 4 (off-set) models
- Provision for mounting 4x4 Equip's Free Standing Light or Shower Pole
- Provision for mounting 4x4 Equip's Combo Shovel
- Divider in base to have the option to carry an axe or shovel on their own

# Axe & Shovel Holder Vehicle Matrix for OEM Rim & Tyre

**Please Note:**  
Due to manufacturer variations , confirm off-set (see over) before ordering.

Make	Model	Series	Steel Rims	Alloy Rims	Studs	Shovel Holder Model	Mounting Plate - Part No
Holden	Frontera	all			6	M3	IDH-1-40
	Jackaroo	all			6	M3	IDH-1-40
	Jackaroo	all			6	M2	IDH-1-40
Jeep	Wrangler	all			5	M3	IDH-1-41
Land Rover	Defender	all			5	M3	IDH-1-42
	Defender	all			5	M3	IDH-1-43
	Discovery	I			5	M3	IDH-1-42
	Discovery	I			5	M3	IDH-1-43
	Discovery	II			5	M3	IDH-1-42
	Freelander	all			5	M3	IDH-1-41
Mitsubishi	Pajero	NH-NL			6	M3	IDH-1-40
	Pajero	NH-NL			6	M2	IDH-1-40
	Pajero	NM-NP			6	M3	IDH-1-40
Nissan	Patrol GQ	all			6	M2	IDH-1-40
	Patrol GU	I, II, III			6	M2	IDH-1-40
	Patrol GU	IV			6	M2	IDH-1-40
	Patrol GU	IV			6	M1	IDH-1-40
Suzuki	Vitara	all			5	M3	IDH-1-41
	Grand Vitara	all			5	M3	IDH-1-41
	Siera	all			5	M3	IDH-1-41
Toyota	Prado	all			6	M3	IDH-1-40
	Prado	all			6	M2	IDH-1-40
	Troop Carrier				6	M3	IDH-1-40
	Troop Carrier				5	M3	IDH-1-40
	Troop Carrier				5	M2	IDH-1-40
	Rav 4	all			5	M3	IDH-1-41
Hummer	H3	all			5	M3	IDH-1-40
General	Panel Mount	Camper Trailer, Ute or Slide on Camper				M4	NA

**Accessories**

- Combo Shovel (with D Handle) IDH-2-1
- 2Kg (4lb) Fibreglass Handle Axe IDH-30-1
- Threaded Aluminium Telescopic Light & Shower Pole IDH-5-2
- Wire Light Holder IDH-4-1

# AXE AND SHOVEL HOLDER MEASURING INSTRUCTIONS

As you can appreciate, there are many different types and combinations of rims and tyres on the market.

Therefore, it is necessary to measure your rim and tyre combination to select the best suited Axe and Shovel Holder for your Four Wheel Drive.

There are three models to choose from, the M1, M2 and M3, which will cover most rim off-set variations. The model type and mounting plate spigot length is determined by measuring dimensions 'A' and 'B' on alloy rims and dimension 'C' on steel rims.

If you run multiple rims and tyres, select the larger dimension in all cases.

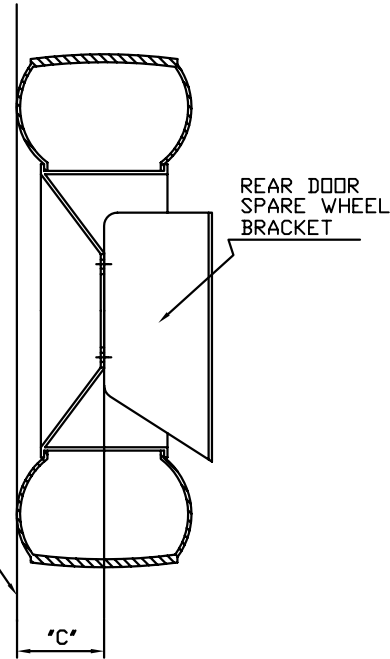
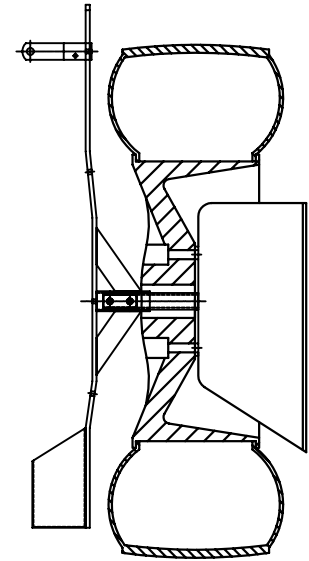
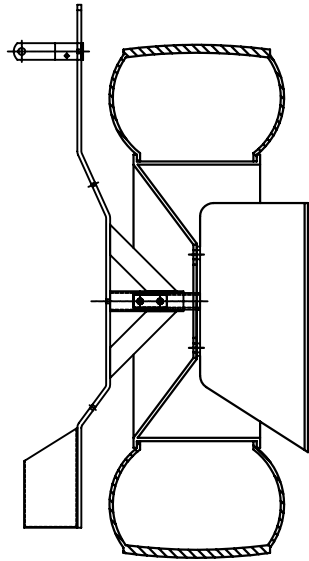

**STEEL RIM**  
 REQUIRE DIMENSION "C"  
 IN MILLIMETERS

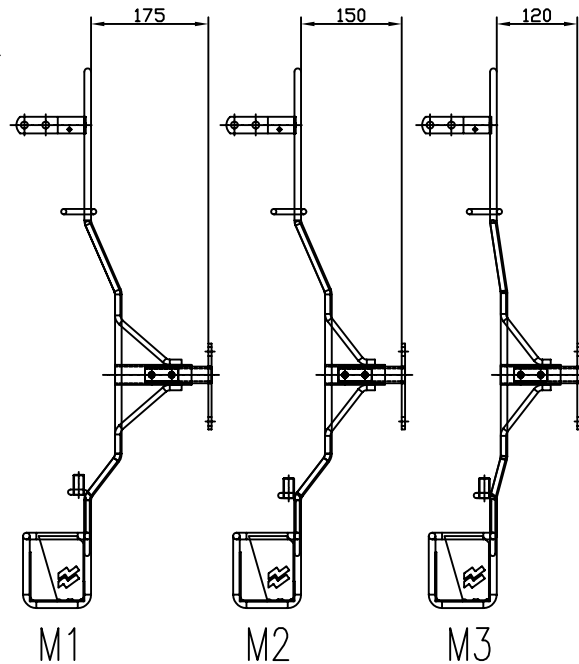

M1

M2

M3

OFF-SET MODELS AVAILABLE

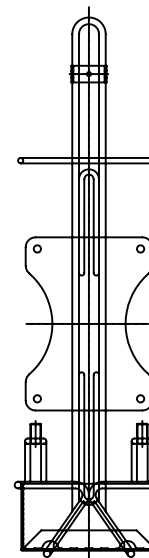

M4 (FLAT PANEL MOUNT)

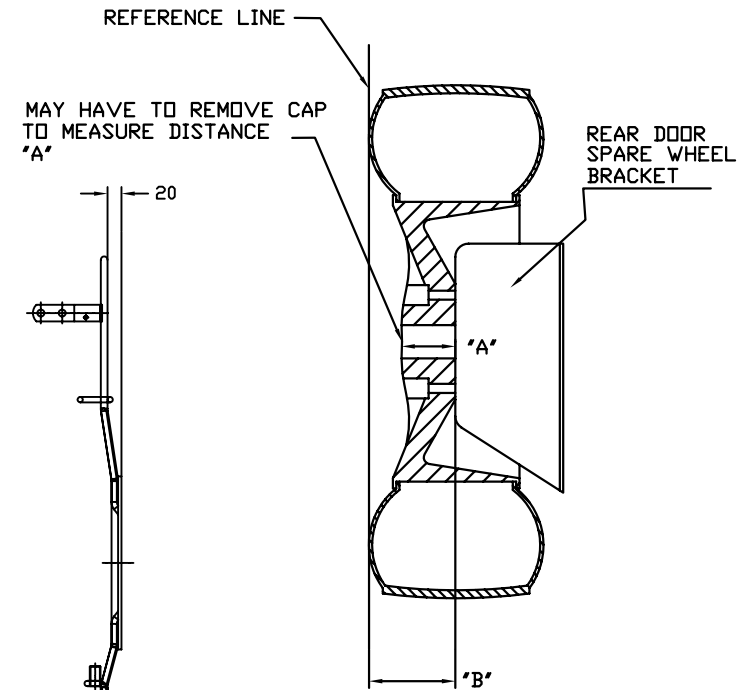

**ALLOY RIM**  
 REQUIRE DIMENSIONS  
 "A" AND "B"  
 IN MILLIMETERS