

GENERAL INFO

EXTRA HEAVY DUTY WATER FILTER HOUSING

The Puretec MPX Series is an extra heavy duty housing with brass inlet and outlet support, rust-proof and anti-flex aluminium bracket, with the peace of mind of Puretec's 10 year guarantee^.

The MPX Series features the new Puretec registered bracket design. These brackets are aesthetically appealing complete with a modern matt black finish that looks great on the side of any house or building. The design however is not only about looks, the new registered design ensures the system is stronger and much more rigid. They are engineered using lightweight materials and feature easy mounting points.

The housing can be used in a wide variety of applications and is compatible with a wide range of water filter cartridges (sold separately). Select a cartridge that best suits your situation/water source. For cartridge selection advice contact your local Puretec dealer or call our Puretec Customer Service Helpline.

FEATURES & BENEFITS

- New integrated rust-proof, anti-flex aluminium wall mount bracket®.
- Peace of mind with whole house or whole building filtration.
- Flow rates up to 160 litres/minute.
- Heavy duty housings for reliable whole house protection.
- Low maintenance, no moving parts.
- No power required.
- Easy to install.
- Internal or external use.
- Wide variety of cartridges available (sold separately).
- 10 year warranty.



CARTRIDGE SUGGESTIONS (SOLD SEPARATELY)

Model Code:	Dirt, Rust, Sediment (Mains Water)	Taste, Odour Removal (Mains Water)	Dirt, Rust, Sediment (Rainwater)	Taste, Odour Removal (Rainwater)
MPX100B	PX05MP1	CB10MP1	PL05MP1	DP10MP1
MPX300B	PX05MP2	CB10MP2	PL05MP2	DP10MP2

FILTER CARTRIDGES NOT INCLUDED

For more information, please visit our website puretecgroupp.com, email us at sales@puretecgroupp.com or call us at **1300 140 140** (AU) **0800 130 140** (NZ).

TECHNICAL INFORMATION

Ordering Code:	MPX100B	MPX300B
Cartridge Size:	4.5" x 10"	4.5" x 20"
Flow*:	80 Lpm	160 Lpm
Inlet/Outlet Connection:	1" BSP	1" BSP
Operating Pressure Min/Max:	0 - 900~ kPa	
Operating Temperature Min/Max:	0 - 38°C (protect from freezing)	
Warranty:	10 years^	

^10 Year warranty is 1 year parts and labour, plus 9 years parts only. *Flow rate is dependent on the filter cartridge used. The application should be designed according to filter cartridge capabilities. ~Note: Where line pressure exceeds 500 kPa, an approved pressure limiting device must be installed to comply with Australian & New Zealand Plumbing Standards. (Ref. AS/NZS 3500.1:2021, Clause 3.3.4).

PRODUCT DIMENSIONS Measurements in Millimeters (mm)

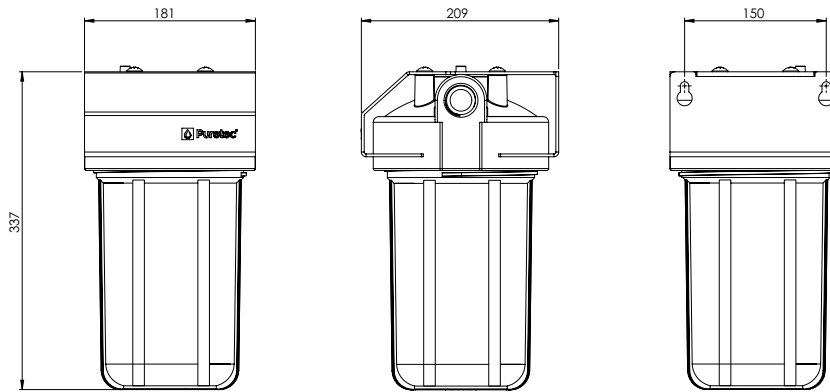
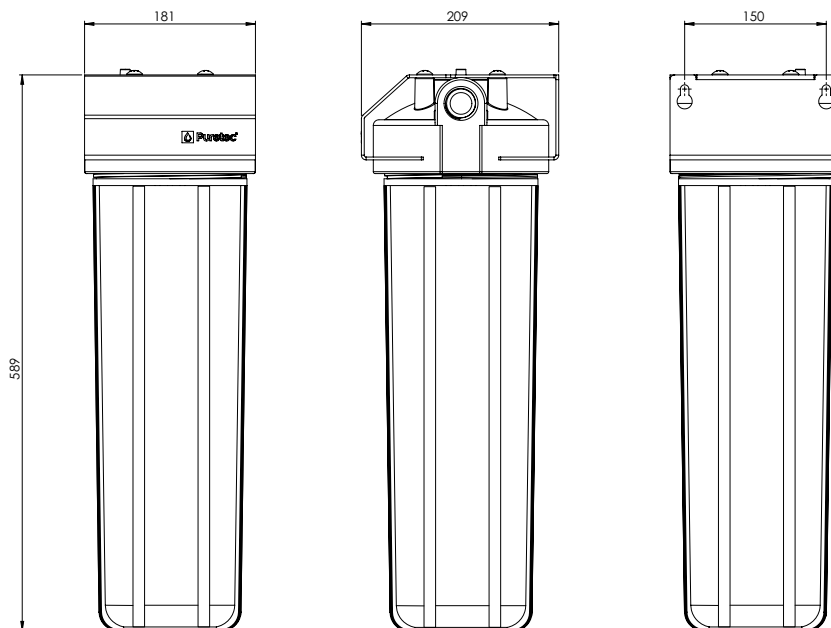
MPX100B

MPX300B

- Note:**
1. No claims can be made based on the specifications and images in this document. The design, technology, colours, features and prices are subject to change.
 2. This document and all its contents are copyright protected. All rights are reserved, particularly alteration, translation and reproduction using electronic systems.
 3. ^Warranties in this document cover parts for the period stated and include cover for parts and labour for the first year where applicable, subject to approval. Our Water Filtration Specialists can provide you with advice to suit your needs.