

Horizontal Multistage Pumps

50 Hz Stainless Steel MH 3 Specifications

Technical data 50Hz

| Single-phase 220-240 V 50 Hz | | Three-phase 380-415 V 50 Hz | | Number of Stages | Motor Power | | Input Power kW | Internal Capacitor | | Rated Current | | |
|---------------------------------|-------------|--------------------------------|-------------|---------------------|----------------|------|----------------------|-----------------------|-----|-----------------------------------|-----------------|-----|
| Model No. | Order No. | Model No. | Order No. | | kW | HP | | μF | V | Single-phase 220-240 V 50Hz | Three-phase | |
| | | | | | | | | | | 220-240 V 50 Hz | 380-415 V 50 Hz | |
| 3AMH2B-51 | 96141003102 | 3AMH2B-53 | 96141003302 | 2 | 0.33 | 0.45 | 0.44 | 16 | 450 | 2.5 | 2.4 | 1.4 |
| 3AMH3B-51 | 96141003103 | 3AMH3B-53 | 96141003303 | 3 | 0.45 | 0.6 | 0.59 | 16 | 450 | 3.0 | 2.6 | 1.5 |
| 3AMH4B-51 | 96141003104 | 3AMH4B-53 | 96141003304 | 4 | 0.55 | 0.75 | 0.75 | 16 | 450 | 3.7 | 2.9 | 1.7 |
| 3AMH5B-51 | 96141003105 | 3AMH5B-53 | 96141003305 | 5 | 0.75 | 1 | 0.90 | 16 | 450 | 4.3 | 3.1 | 1.8 |
| 3AMH6B-51 | 96141003106 | 3AMH6B-53 | 96141003306 | 6 | 0.9 | 1.2 | 1.14 | 30 | 450 | 5.4 | 4.3 | 2.5 |
| 3AMH7B-51 | 96141003107 | 3AMH7B-53 | 96141003307 | 7 | 1.1 | 1.5 | 1.29 | 30 | 450 | 6.0 | 4.7 | 2.7 |
| 3AMH8B-51 | 96141003108 | 3AMH8B-53 | 96141003308 | 8 | 1.3 | 1.8 | 1.46 | 30 | 450 | 6.9 | 5.5 | 3.2 |
| 3AMH9B-51 | 96141003109 | 3AMH9B-53 | 96141003309 | 9 | 1.5 | 2 | 1.61 | 30 | 450 | 7.5 | 5.9 | 3.4 |

Single-phase motors: 220-240 V ± 5 % / 50 Hz. Thermal protection built into the motor.

Three-phase motors: 380-415 V ± 5 % / 50 Hz. Thermal protection to be provided into the starter panel by the installer.

Dimensions and weights

| Single-phase 220-240 V 50 Hz | Three-phase 380-415 V 50 Hz | Dimensions | | | | | | | | Packaging | | | | |
|---------------------------------|--------------------------------|------------|---------|---------|---------|---------|---------|---------|--------------|-----------|---------|---------|---------|-------------|
| Model No. | Order No. | A mm | E mm | C mm | D mm | F mm | G (mm) | | DN1 | DN2 | L mm | B mm | H mm | Weight (kg) |
| | | | | | | | 1-phase | 3-phase | | | | | | |
| 3AMH2B-51 | 3AMH2B-53 | 103 | 256 | 139.6 | 173 | 359 | 120 | 118 | BSP 1.25" | BSP 1" | 500 | 200 | 260 | 10.5 |
| 3AMH3B-51 | 3AMH3B-53 | 103 | 256 | 139.6 | 173 | 359 | 120 | 118 | | | 500 | 200 | 260 | 10.6 |
| 3AMH4B-51 | 3AMH4B-53 | 127 | 256 | 163.6 | 197 | 383 | 120 | 118 | | | 500 | 200 | 260 | 11.1 |
| 3AMH5B-51 | 3AMH5B-53 | 151 | 256 | 187.6 | 221 | 407 | 120 | 118 | | | 500 | 200 | 260 | 11.6 |
| 3AMH6B-51 | 3AMH6B-53 | 175 | 256 | 211.6 | 245 | 431 | 120 | 118 | | | 500 | 200 | 260 | 14.0 |
| 3AMH7B-51 | 3AMH7B-53 | 199 | 256 | 235.6 | 269 | 455 | 120 | 118 | | | 610 | 220 | 260 | 14.6 |
| 3AMH8B-51 | 3AMH8B-53 | 223 | 300 | 259.6 | 293 | 523 | 125 | 125 | | | 610 | 220 | 260 | 18.1 |
| 3AMH9B-51 | 3AMH8B-53 | 247 | 300 | 283.6 | 317 | 547 | 125 | 125 | | | 610 | 220 | 260 | 18.7 |

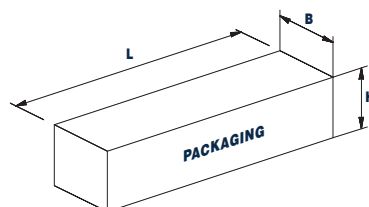
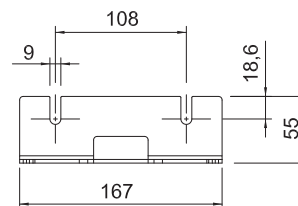
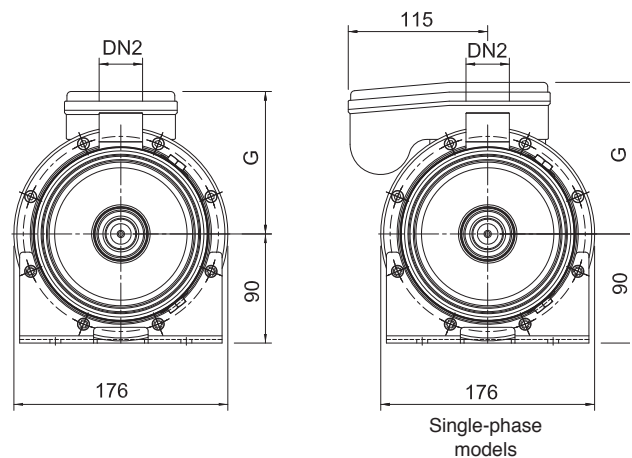
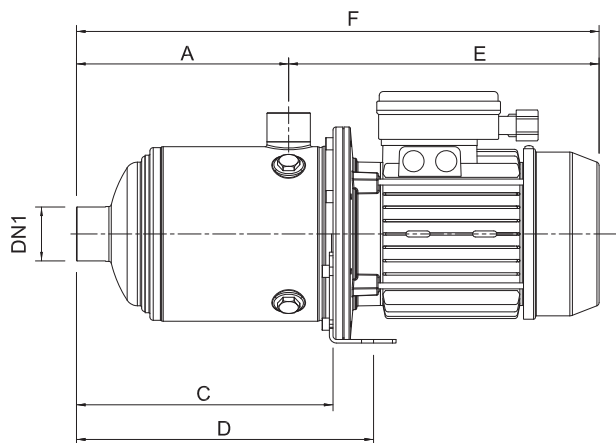

Horizontal Multistage Pumps

50 Hz Stainless Steel MH 3 Specifications

