

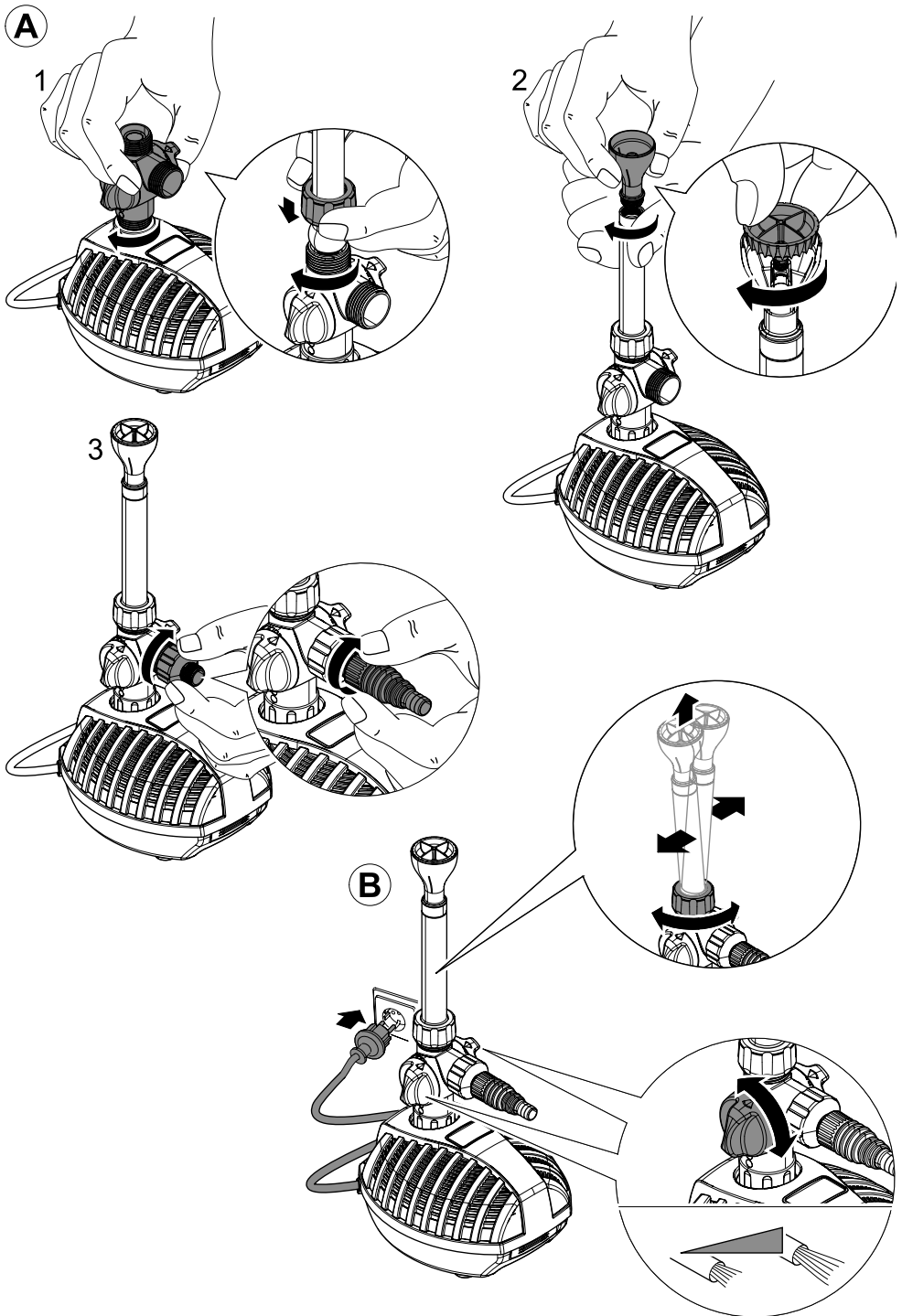

Aquarius Fountain Set 1000, 1500, 2500, 3500

- DE Gebrauchsanleitung
- GB Operating instructions
- FR Notice d'emploi
- NL Gebruiksaanwijzing
- ES Instrucciones de uso
- PT Instruções de uso
- IT Istruzioni d'uso
- DK Brugsanvisning
- NO Bruksanvisning
- SE Bruksanvisning
- FI Käyttöohje
- HU Használati útmutató
- PL Instrukcja użytkowania
- CZ Návod k použití
- SK Návod na použitie
- SI Navodila za uporabo
- HR Uputa o upotrebi
- RO Instrucțiuni de folosință
- BG Упътване за употреба
- UA Посібник з експлуатації
- RU Руководство по эксплуатации
- CN 使用说明书





C

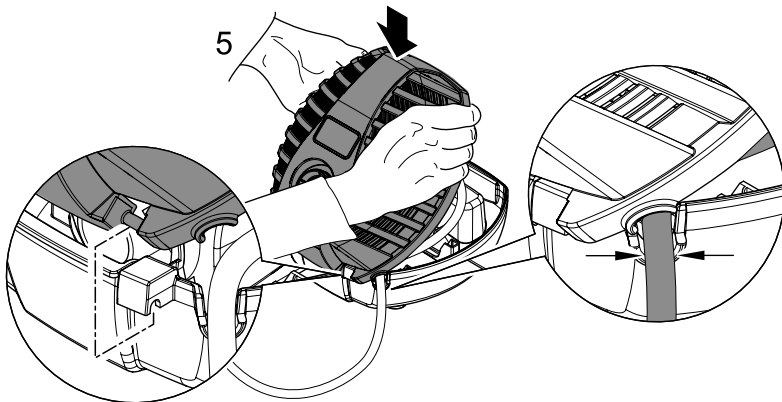
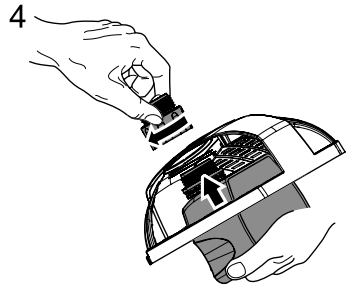
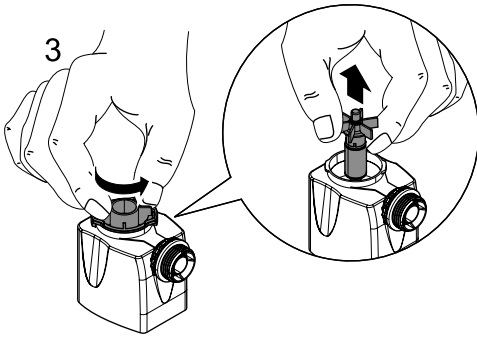
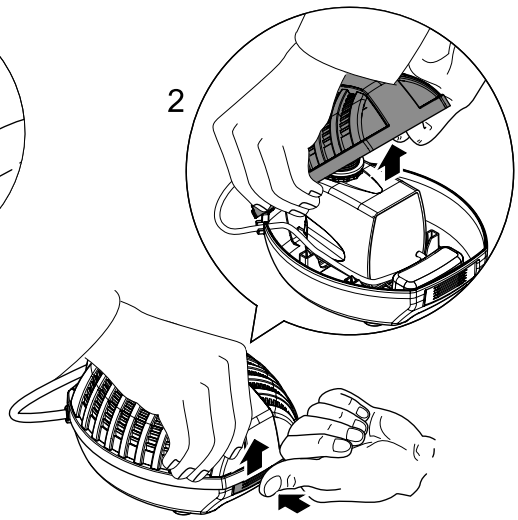
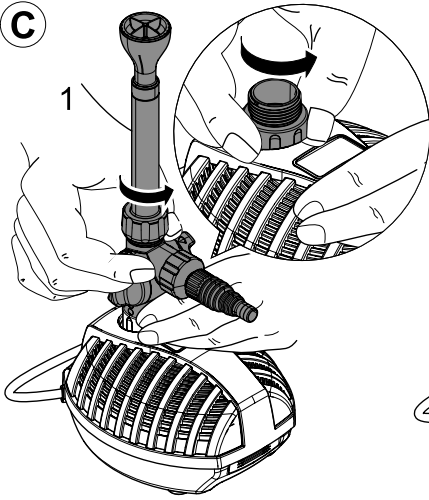

Translation of the original Operating Instructions

Information about these operating instructions

Welcome to OASE Living Water. You made a good choice with the purchase of the product **Aquarius Fountain Set 1000, 1500, 2500, 3500**.

Prior to commissioning the unit, please read the instructions of use carefully and fully familiarise yourself with the unit. Ensure that all work with this unit is only carried out in accordance with these instructions.

Adhere to the safety information for the correct and safe use of the unit.

Keep these instructions in a safe place! Please also hand over the instructions when passing the unit on to a new owner.

Symbols

The symbols used in this operating manual have the following meanings:



Risk of injury to persons due to dangerous electrical voltage

This symbol indicates an imminent danger, which can lead to death or severe injuries if the appropriate measures are not taken.



Risk of injury to persons due to a general source of danger

This symbol indicates an imminent danger, which can lead to death or severe injuries if the appropriate measures are not taken.



Important information for trouble-free operation.

Intended use

Aquarius Fountain Set 1000, 1500, 2500, 3500, in the following termed "unit", and all other parts from the delivery scope may be used exclusively as follows:

- For pumping normal pond water for water features and fountains.
- Operation under observance of the technical data.

The following restrictions apply to the unit:

- Do not use in swimming ponds.
- Never use the unit to convey fluids other than water.
- Never run the unit without water.
- Do not use for commercial or industrial purposes.
- Do not use in conjunction with chemicals, foodstuff, easily flammable or explosive substances.



Attention! Risk of damage!

Ensure that the unit does not take in air or run dry. Do not connect the unit to the domestic water lines.

Safety information

The company **OASE** has built this unit according to the state of the art and the valid safety regulations. Despite the above, hazards for persons and assets can emanate from this unit if it is used in an improper manner or not in accordance with its intended use, or if the safety instructions are ignored.

For safety reasons, children and young persons under 16 years of age as well as persons who cannot recognise possible danger or who are not familiar with these operating instructions, are not permitted to use the unit. Keep children under supervision to ensure that they do not play with the unit.

Hazards encountered by the combination of water and electricity

- The combination of water and electricity can lead to death or severe injury from electrocution, if the unit is incorrectly connected or misused.
- Prior to reaching into the water, always switch off the mains voltage to all units used in the water.

Correct electrical installation

- Electrical installations must meet the national regulations and may only be carried out by a qualified electrician.
- A person is regarded as a qualified electrician, if, due to his/her vocational education, knowledge and experience, he or she is capable of and authorised to judge and carry out the work commissioned to him/her. Working as a qualified person also includes the recognition of possible hazards and the adherence to the pertinent regional and national standards, rules and regulations.
- For your own safety, please consult a qualified electrician.
- The unit may only be connected when the electrical data of the unit and the power supply coincide. The unit data is to be found on the unit type plate or on the packaging, or in this manual.
- Ensure that the unit is fused for a rated fault current of max. 30 mA by means of a fault current protection device.

- Extension cables and power distributors (e.g. outlet strips) must be suitable for outdoor use.
- Ensure that the power connection cable cross section is not smaller than that of the rubber sheath with the identification H05RN-F. Extension cables must meet DIN VDE 0620.
- Protect the plug connections from moisture.
- Only plug the unit into a correctly fitted socket.

Safe operation

- Never operate the unit if either the electrical cables or the housing are defective!
- Do not carry or pull the unit by its electrical cable.
- Route all cables such that damage is excluded and nobody can trip over them.
- Never open the unit housing or its attendant components, unless this is explicitly required in the operating instructions.
- Only use original spare parts and accessories for the unit.
- Never carry out technical modifications to the unit.
- Only have repairs carried out by customer service points authorised by OASE.
- The power connection cables cannot be replaced. When the cable is damaged, the unit or the component needs to be disposed of.
- Only operate the unit if no persons are in the water!
- Keep the socket and power plug dry.

Important! The unit is equipped with a permanent magnet. The magnetic field may affect the function of pacemakers.

Installation



Attention! Dangerous electrical voltage.

Possible consequences: Death or severe injury.

Protective measures:

- Prior to reaching into the water, disconnect the power supply to all units used in the water.
- Disconnect the power plug prior to carrying out work on the unit.

Screw T distributor to the connection socket, screw nozzle tube to the T distributor (A1). Screw nozzle mounting and the desired water feature nozzle to the nozzle tube (A2). It is possible to connect a hose to the lateral outlet at the T distributor by means of the reduction element and the stepped hose connection (A3). Place the unit in the pond horizontally on firm, sludge-free ground and ensure that it is completely covered with water (at a maximum of 2 m below the water level).

Align the nozzle tube. The water feature height and the water flow can be adjusted with a regulator at the lateral outlet at the T distributor (B). The power supply must be disconnected to switch off the unit.

Start-up



Attention! Sensitive electrical components.

Possible consequence: The unit will be destroyed.

Protective measure: Do not connect the unit to a dimmable power supply.



Attention! The pump must never run dry.

Possible consequence: The pump will be destroyed.

Protective measure: Check the water level at regular intervals. Always place the unit below water level.



Attention! The installed temperature monitor automatically turns the pump off, if it is overloaded. The pump automatically switches on again once the motor has cooled down. **Risk of accident!**

This is how to connect the power supply:

Switching on: Connect power plug to the socket. The unit switches on immediately when the power connection is established.

Switching off: Disconnect the power plug.

Maintenance and cleaning



Attention! Dangerous electrical voltage.

Possible consequences: Death or severe injury.

Protective measures:

- Prior to reaching into the water, disconnect the power supply to all units used in the water.
- Disconnect the power plug prior to carrying out work on the unit.

If necessary, clean the unit with clear water using a soft brush.

- Never use aggressive cleaning agents or chemical solutions. These could attack the housing surface or impair the function.
- In the event of stubborn furring (calcium deposits), a common household cleaner free from vinegar and chlorine can be used. Subsequently, clean the pump thoroughly using clear water.

Cleaning the unit

Unscrew the nozzle tube including T distributor and connection socket (C1). Open strainer casing and remove pump (C2). Unscrew pump lid and remove impeller (C3). Clean all components using clear water and a brush. After cleaning the pump, reassemble in the reverse order. Insert pump in the strainer casing (C4). Route connection cable such that it cannot be pinched. Refit strainer lid and close (C5).

Malfunctions

Malfunction	Cause	Remedy
The unit is not operating	No mains voltage	Check mains voltage
Insufficient delivery rate	Impeller blocked	Clean impeller
	Strainer casing clogged	Clean strainer casing
	Excessive pressure losses in the hoses	Reduce hose length and connecting parts to a minimum, route hoses as straight as possible
Unit switches off after a short running period	Water temperature too high	Note maximum water temperature of +35°C

Disposal



Do not dispose of this unit with domestic waste! For disposal purposes, please use the return system provided. Disable the unit beforehand by cutting off the cables.

Storage/Over-wintering

Remove the unit at temperatures below zero degrees centigrade. Thoroughly clean and check the unit for damage.



Store the unit immersed in water or filled with water in a frost-free place. Do not flood the power plug!

Repair

A damaged housing cannot be repaired and must be put out of operation. Dispose of the unit in accordance with the regulations.

DE	Typ	Abmessungen	Gewicht	Bemessungsspannung	Leistungsaufnahme	Förderleistung	Wassersäule	Anschlüsse	Wassertemperatur
GB	Type	Dimensions	Weight	Rated voltage	Power consumption	Max. flow rate	Max. head height	Connections	Water temperature
FR	Type	Dimensions	Poids	Tension de mesure	Puissance absorbée	Capacité de refoulement	Colonne d'eau	Raccordements	Température de l'eau
NL	Type	Afmetingen	Gewicht	Dimensioneringsspanning	Vermogensopname	Pompcapaciteit	Waterkolom	Aansluitingen	Watertemperatuur
ES	Tipo	Dimensiones	Peso	Tensión asignada	Consumo de potencia	Capacidad de elevación	Columna de agua	Conexiones	Temperatura del agua
PT	Tipo	Dimensões	Peso	Voltagem considerada	Consumo absorvida	Débito	Coluna de água	Conexões	Temperatura da água
IT	Tipo	Dimensioni	Peso	Tensione di taratura	Potenza assorbita	Portata	Colonna d'acqua	Allacciamenti	Temperatura dell'acqua
DK	Type	Dimensioner	Vægt	Nominal spænding	Effektforbrug	Pumpekapacitet	Vandsøjle	Tilslutninger	Vandtemperatur
NO	Type	Mål	Vekt	Merkespennning	Effektforbruk	Kapasitet	Vannseyle	Tilkoblinger	Vanntemperatur
SE	Typ	Mått	Vikt	övre märkspänning	Effekt	Måtningsprestanda	Vattenpelare	Anslutningar	Vatten temperatur
FI	Tyyppi	Mitat	Paino	mitoitusjännite	Tehonotto	Pumpun teho	Vesipatsas	Liitännät	Veden lämpötila
HU	Típus	Méreték	Súly	mért feszültség	Teljesítményfelvétel	Szállítási teljesítmény	Vízoszlop	Csatlakozók	Víz hőmérséklet
PL	Typ	Wymiary	Ciężar	napięcie znamionowe	Pobór mocy	Wydajność pompowania	Stup wody	Przyłącza	Temperatura wody
CZ	Typ	Rozměry	Hmotnost	domezovací napětí	Přikon	Dopravný výkon	Vodní sloupec	Připojky	Teplota vody
SK	Typ	Rozměry	Hmotnosť	dimenzijné napätie	Přikon	Dopravný výkon	Vodný slúpec	Pripojky	Teplota vody
SI	Tip	Dimenzije	Teža	dimenzionirana napetost	Poraba moči	Črpalna zmogljivost	Vodni stebel	Priključki	Temperatura vode
HR	Tip	Dimenzije	Težina	gorji nazivni napon	Potrošnja energije	Protokni kapacitet	Vodeni stup	Priključci	Temperatura vode
RO	Tip	Dimensiuni	Greutate	tensiunea măsurată	Putea consumată	Debit de pompare	Soloană de apă	Solexioni	Temperatura apei
BG	Тип	Размери	Тегло	номинално напрежение	Потребявана мощност	Дебит	Воден стълб	връзки/изходи	Температурата на водата
UA	Тип	Розміри	Вага	розрахункова напруга	Споживання електроенергії	Продуктивність	Водяний стовп	Підключення	Температура води
RU	Тип	Размеры	Вес	расчетное напряжение	Потребление мощности	Производительность	Водяной столб	Соединения	Температура воды
CN	型号	尺寸	重量	设计电压	耗用功率	输送能力	水柱	接头	水温
Aquarius Fountain Set	1000 1500 2500 3500	202x182x142 mm	1.8 kg 2.0 kg 2.3 kg 2.8 kg	~ 220-240 V, 50 Hz	11 W 25 W 40 W 70 W	≤ 1.000 l/h ≤ 1.500 l/h ≤ 2.500 l/h ≤ 3.400 l/h	≤ 1.3 m ≤ 1.9 m ≤ 2.2 m ≤ 2.7 m	1 "	+4 ... +35 °C

	IP 68  2 m				
DE	Staubdicht. Wasserdicht bis 2 m Tiefe	Bei Frost das Gerät deinstallieren	Mögliche Gefahren für Personen mit Herzschrittmachern!	Nicht mit normalem Hausmüll entsorgen!	Achtung! Lesen Sie die Gebrauchsanleitung
GB	Dust tight. Submersible to 2 m depth.	Remove the unit at temperatures below zero (centigrade).	Possible hazard for persons wearing pace makers!	Do not dispose of together with household waste!	Attention! Read the operating instructions
FR	Imperméable aux poussières. Étanche à l'eau jusqu'à une profondeur de 2 m	Retirez l'appareil en cas de gel	Dangers possibles pour des personnes ayant des stimulateurs cardiaques !	Ne pas recycler dans les ordures ménagères !	Attention ! Lire la notice d'emploi
NL	Stofdicht. Waterdicht tot een diepte van 2 m	Bij vorst het apparaat deïnstalleren	Mogelijke gevaren voor mensen met een pacemaker!	Niet bij het normale huisvuil doen!	Let op! Lees de gebruiksaanwijzing
ES	A prueba de polvo. Impermeable al agua hasta 2 m de profundidad	Desinstale el equipo en caso de heladas	Posibles peligros para las personas con marcapasos.	¡No deseche el equipo en la basura doméstica!	¡Atención! Lea las instrucciones de uso
PT	A prova de pó. A prova de água até 2 m de profundidade.	Em caso de geada, desinstalar o aparelho	Eventuais perigos para pessoas com pace-makers!	Não deitar ao lixo doméstico!	Atenção! Leia as instruções de utilização
IT	A tenuta di polvere. Impermeabile all'acqua fino a 2 m di profondità.	In caso di gelo disinstallare l'apparecchio	Possibili pericoli per persone con pace-maker!	Non smaltire con normali rifiuti domestici!	Attenzione! Leggete le istruzioni d'uso!
DK	Støvtæt. Vandtæt ned til 2 m dybde	Ålmonter apparatet ved frostvejr	Mulig fare for personer med pacemaker	Må ikke bortskaffes med det almindelige husholdningsaffald	OBS! Læs brugsanvisningen
NO	Støvtett. Vanntett ned til 2 m dyp	Ved frost, demonter apparatet	Kan være farlig for personer med pacemaker!	Ikke kast i alminnelig husholdningsavfall!	NB! Les bruksanvisningen
SE	Damtät. Vattentät till 2 m djup	Demontera apparaten innan första frosten.	Möjlig risk för personer med pacemaker!	Får inte kastas i hushållssoptorna!	Varning! Läs igenom bruksanvisningen
FI	Pölytiivis. Vesitiivis 2 m syvyteen asti.	Läite purettava ennen pakkausia	Mahdollinen vaara sydämentahdistinta käyttäville henkilöille!	Älä hävittää laitetta tavallisen talousjätteen kanssa!	Huomio! Lue käyttöohje
HU	Portómített. Vízálló 2 m-es mélységig	Fagy esetén a készüléket szerelje le	A készülék veszélyes lehet szívritmus-szabályozóval rendelkező személyekre!	A készüléket nem a normál háztartási szeméttel együtt kell megsemmisíteni!	Figyelem! Olvassa el a használati útmutatót
PL	Pyłoszczelny. Wodoszczelny do 2 m głębokości.	W razie mrozu zdeinstalować urządzenie	Możliwość wystąpienia zagrożenia dla osób ze stymulatorami	Nie wyrzucać wraz ze śmieciami domowymi!	Uwaga! Przeczytać instrukcję użytkowania!
CZ	Prachotěsný. Vodotěsný do hloubky 2 m	Při mrazu přístroj odinstalovat	Možná nebezpečí pro osoby s kardiostimulátory!	Nelikvidovat v normálním komunálním odpadu!	Pozor! Přečtěte Návod k použití!
SK	Prachotesný. Vodotesný do hĺbky 2 m	Pri mraze prístroj odinštalovať	Možné nebezpečenstvo pre osoby s kardiostimulátormi!	Nelikvidovať v normálnom komunálnom odpade!	Pozor! Prečítajte si Návod na použitie
SI	Ne prepušča prahu. Vodotesno do globine 2 m.	Ob zmrzali demontirajte napravo.	Obstaja nevarnost za ljudi s srčnim spodbujevalnikom!	Ne zavrzite skupaj z gospodinjjskimi odpadki!	Pozor! Preberite navodila za uporabo!
HR	Ne propušta prašinu. Ne propušta vodu do 2 m dubine.	U slučaju mraza deinstalirajte uređaj.	Moguće opasnosti za nositelje elektrostimulatora!	Nemojte ga bacati u običan kućni otpad!	Pažnja! Pročitajte upute za upotrebu!
RO	Etanș la praș. Etanș la apă până la o adâncime de 2 m.	Dezinstalați aparatul pe timp de îngheț	Posibile pericole pentru persoane cu by-pass cardiac !	Nu aruncați în gunoierul menajer !	Atenție ! Citiți instrucțiunile de utilizare !
BG	Зaщитено от прах. Водоустойчив до дълбочина 2 м	При ниски температури и опасност от замръзване деинсталирайте уреда	Възможен риск за хора с пейсмейкър!	Не изхвърляйте заедно с обикновените домакински боклук!	Внимание! Прочетете упътването
UA	Пилонепроникний. Водонепроникний до 2 м	Перед морозами пристрій необхідно демонтувати	Небезпека для осіб з кардіостимулятором	Не викидайте разом із побутовим сміттям!	Увага! Читайте інструкцію.
RU	Пыленепроницаемый, водонепроницаемый на глубине до 2 м	При наступлении морозов прибор демонтировать	Возможная опасность для лиц с кардиостимулятором!	Не утилизировать вместе с домашним мусором!	Внимание! Прочитайте инструкцию по использованию
CN	防尘。防水水深至 2 米	霜冻时拆卸设备	可能对带有心脏起搏器人员有危险!	不要同普通的家庭垃圾一起丢弃!	注意! 请阅读使用说明书。

Aquarius				
Pos.	1000	1500	2500	3500
1	35717	35717	35717	35717
2	20830	20830	20830	20830
3	29140	29140	29140	29140
4	29139	29139	29139	29139
5	28351	28352	35755	35756
6	35762	35769	35770	35771

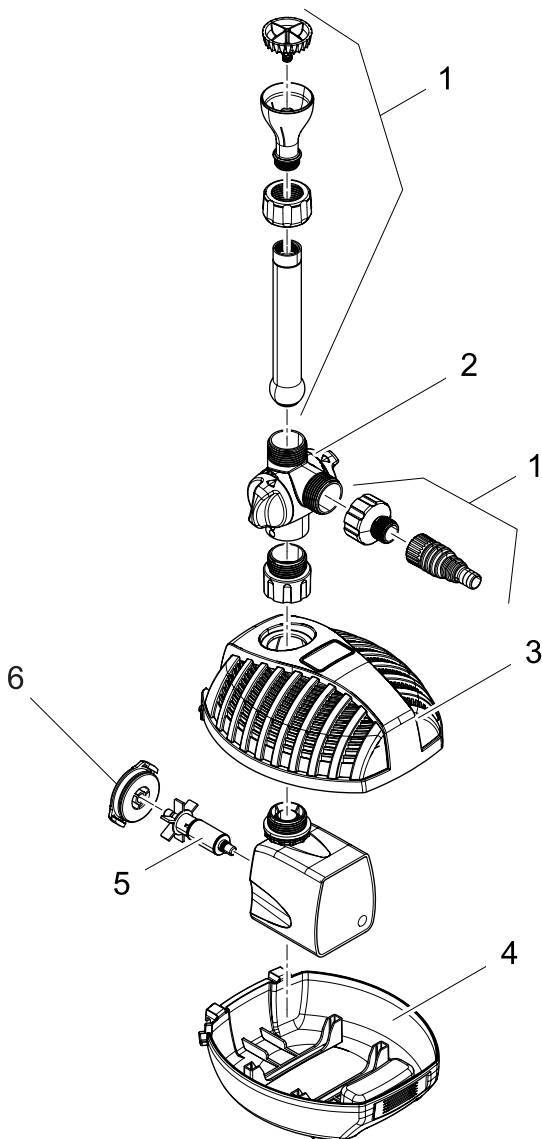



OASE GmbH · www.oase-livingwater.com

Tecklenburger Straße 161 · 48477 Hörstel · Postfach 20 69 · 48469 Hörstel · Germany



15304/04F