

UNILIFT KP



The UNILIFT KP is a lightweight, single-stage pump with a semi-open impeller. They are designed for liquid transfer and pumping of drain water and grey wastewater containing particles up to a size of Ø10. All UNILIFT KP pumps are mostly made of stainless steel, with a stainless steel sleeve for cooling during operation. The pumps are small and handy, suitable for permanent installation or as a portable pump. The suction strainer at the bottom of the pump prevents particles larger than the pump is designed for from entering. The suction strainer is clipped on to the pump housing for easy removal, in case of maintenance.

All UNILIFT KP pumps can be supplied with or without float switch, for automatic or manual operation.



FEATURES

Lightweight and robust

The KP is a lightweight pump designed specifically for drainage jobs. Its stainless steel surface makes it robust, durable and corrosion free, which reduces maintenance to an absolute minimum.

Wet runner

The pump is designed with a canned rotor, which hermetically seals the rotor from the stator. This eliminates the need for a shaft seal, making the pump highly reliable and service friendly.

Prevention of backflow

An optional non-return flap valve can be fitted in the outlet in order to prevent backflow when the pump stops operating.

Thermal overload protection

The single-phase version is effectively protected against any accidental overload, by built-in thermal protection. This means that no additional motor protection is required.

Auto-restart

In case the motor cuts out due to thermal overload, the motor automatically starts again when it has cooled to normal temperature.

Handy and easily transportable

The carry handle mounted on the pump housing makes it handy and easily transportable.

Option for automatic operation

The pumps are available with float switches for automatic on/off operation between two liquid levels or with vertical float for operation in confined areas.

APPLICATIONS

- Domestic wastewater



PERFORMANCE

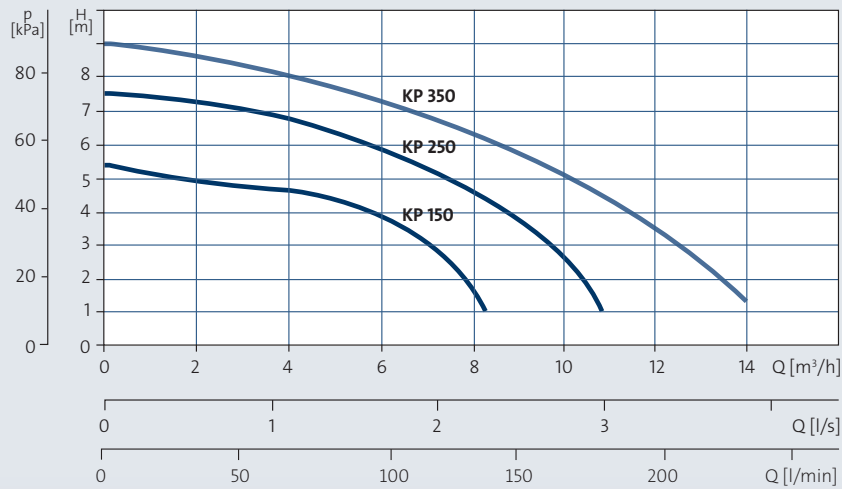

OPERATING CONDITIONS

Liquid temperature

0 °C to 50 °C

Max. particle size

Ø10 mm

pH concentration

4 to 9

Max. installation depth

10 m

TECHNICAL DATA

Mains voltage

1 x 240 V, 50 Hz

Enclosure class

IP68

Insulation class

F

Cable type

H07RN-F

Approvals and markings

CE, LGA, VDE, GS, EMV, GOST, UL, CSA and C-tick

DIMENSIONS

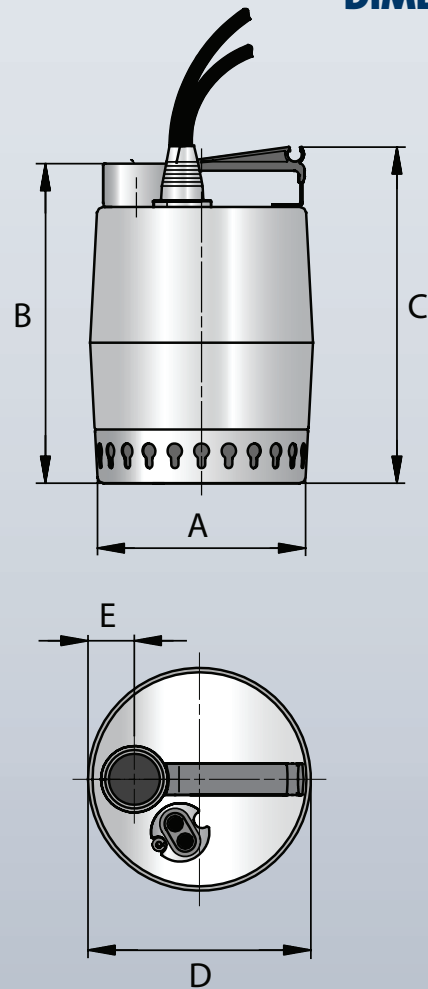

Model	Cable length (m)	Power - P2 (kW)	Connection size	Dimensions (mm)					Weight (kg)
				A	B	C	D	E	
UNILIFT KP 150	5	0.14	1¼" F	140	220	226	148	30	6.3
UNILIFT KP 250	5	0.25	1¼" F	140	220	226	148	30	6.6
UNILIFT KP 350	5	0.35	1¼" F	140	220	226	148	30	7.2