



Products: Leaf Eater Ultra™

Code: RHUL01 - 90mm
RHUL02 - 100mm

The Ultimate in Innovation, Design and Performance.

Product Description

Keeps your Rain Harvesting system free of mosquitoes, vermin and debris.

The Leaf Eater Ultra™ is the next generation Rain Head, featuring the new Hydro Activated Filtration technology and VH Pivot™ outlet. The Leaf Eater Ultra™ Rain Head prevents debris from entering the Rain Harvesting system, improves water quality and reduces tank maintenance. The Leaf Eater Ultra™ uses the Leaf Slide which deflects debris away from the screen and a precisely angled vibrating screen which directs leaves and debris away from the flow of water to maximise catchment efficiency. This Rain Head also incorporates a VH Pivot™ outlet that swivels to suit vertical or horizontal downpipes. The Leaf Eater Ultra™ can also be used as a debris removing device even when rainwater is not being collected.

Features and Benefits

- This Rain Head is a combination of a modern, sleek design and the latest Rain Head technology – the ultimate in Rain Heads
- Integrated cover and cap to compliment modern and classic architecture
- Leaf Eater Ultra™ uses the Leaf Slide and a precisely angled vibrating screen to deflect debris off the screen, for high flow rate performance. (Hydro Activated Filtration™ technology)
- A single mosquito proof stainless steel mesh screen with 0.955mm aperture
- Minimal maintenance required
- Pivot the outlet to suit vertical or horizontal (rear outlet) downpipes (VH Pivot™)
- Maximises the catchment efficiency at low and high flow rates
- Multi-fit cap – 90mm, 100mm, 100mm x 75mm and 100mm x 50mm

Compliance

- Queensland Development Code MP 4.2 – Water Saving Targets
- AS/NZS 3500.3:2003 Plumbing and Drainage – Stormwater Drainage
- HB230:2008 Rainwater Tank Design and Installation Handbook
- enHealth Council – Guidance on the Use of Rainwater Tanks – Preventing Mosquitoes Breeding
- Queensland Health Regulations 1996 (Part 8 – Mosquito Prevention)

Installation

Gutter-Mount Installation

1. Remove and discard the cap.
2. Measure and remove 308mm of downpipe from the bottom of the gutter outlet. Ensure all edges are clean and smooth.
3. Remove the front cover by flexing outwards at the top.
4. Insert the Leaf Eater Ultra™ by sliding the outlet into the bottom section of downpipe.
5. Screw the Leaf Eater Ultra™ into position through the screw slots provided. Ensure appropriate screws and anchors (if required) are used.
6. Check the placement of the Vibrating Screen. It must sit behind and below the front face (refer figure 1).
7. Insert the Leaf Slide into slot holes (refer figure 2).
8. Re-install the front cover.

Mid-Mount Installation

1. Measure and remove 308mm of downpipe from where Leaf Eater Ultra™ is to be situated. Ensure all edges are clean and smooth.
2. Remove the cap and use snips to remove a section to fit the appropriate downpipe.
3. Remove the front cover by flexing outwards at the top.
4. Slide the cap up the top section of downpipe and hold temporarily in place.
5. Insert the Leaf Eater Ultra™ by sliding the outlet into the bottom section of downpipe. The back fixing plate must sit behind the top section of downpipe.
6. Screw the Leaf Eater Ultra™ into position through the screw slots provided. Ensure appropriate screws and anchors (if required) are used.
7. Check the placement of the Vibrating Screen. It must sit behind and below the front face (refer figure 1).
8. Insert the Leaf Slide into slot holes (refer figure 2).
9. Re-install the front cover.
10. Slide the cap back down the downpipe until it sits securely on the top of the Leaf Eater Ultra™.

Horizontal (Rear Outlet) Installation

1. If installing under gutter remove and discard cap. If installing mid-mount carefully use snips to remove a section of cap to fit the appropriate downpipe.
2. Swivel the outlet to the horizontal position - some force may be required.
3. Remove the front cover by flexing outwards at the top.
4. Position the Leaf Eater Ultra™ next to the existing downpipe, mark and cut top and bottom cut lines. Ensure all cut edges are clean and smooth.
5. Slide the cap up the top section of downpipe and hold temporarily in place.
6. Insert the Leaf Eater Ultra™ by sliding the rear outlet into the horizontal pipe. The back fixing plate must sit behind the top section of downpipe.
7. Screw the Leaf Eater Ultra™ into position through the screw slots provided. Ensure appropriate screws and anchors (if required) are used.
8. Check the placement of the Vibrating Screen. It must sit behind and below the front face (refer figure 1).
9. Insert the Leaf Slide into slot holes (refer figure 2).
10. Re-install the front cover.
11. Slide the cap back down the downpipe until it sits securely on the top of the Leaf Eater Ultra™.

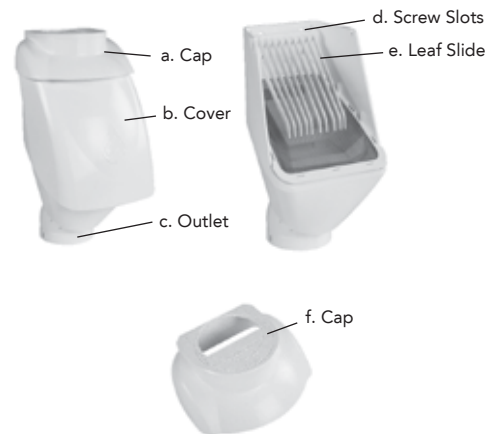

Figure 1.

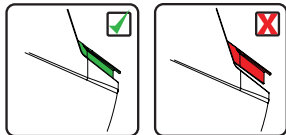
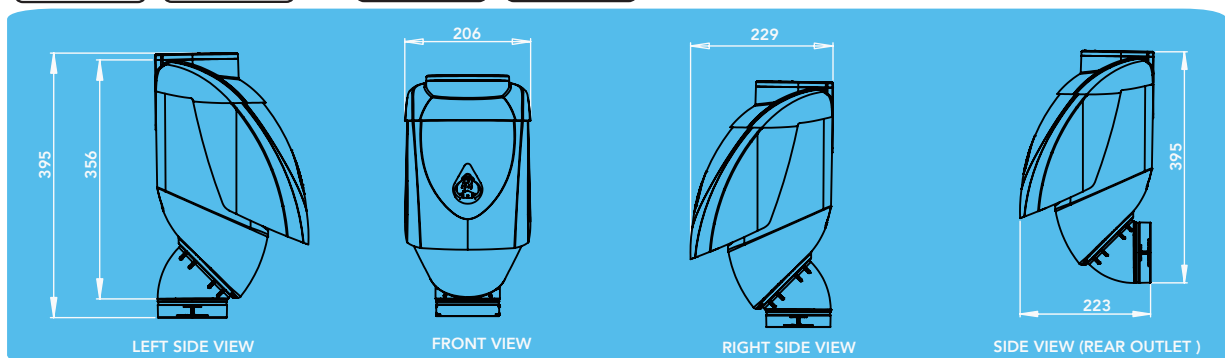
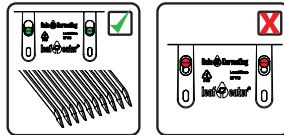

Figure 2.



ALL DIMENSIONS IN MM UNLESS OTHERWISE STATED.

Maintenance

The Hydro Activated Filtration™ technology is mostly self cleaning. If cleaning is required simply hose or brush off the screen.